

923-ST1SUM FC

Rate/Total Flow Computer for Sum of 2 Flowmeters in Liquid Applications

- Displays Rate/Total of Meter 1, Meter 2 and Sum of Meter 1 & Meter 2
- Supports Pulse Producing Flowmeters Turbine, Positive Displacement, Coriolis, Compound Flowmeters
- Volume, Corrected Volume or Mass Equation
- Universal Viscosity Curve (UVC) and Strouhal/Roshko Advanced Linearization Methods
- API 2540 Equations for Petroleum Fluids
- User Entry of Fluid Properties (10 Selectable)
- Menu Selectable Hardware & Software Features
- Data Logging of Sum of Rate/Total



- Two Line LCD, OLED or VFD Display
- Isolated Pulse and Analog Outputs Standard
- RS-232 Port Standard, RS-485 Optional
- Windows™ Setup Software
- DDE Server & HMI Software Available

Sum Liquid Application

Measurements:

Flowmeter sensors measure the actual flow in either two separate lines or in a compound flowmeter. A temperature sensor can also be installed to correct for UVC or STRO linearization of turbine flowmeters.

Calculations:

The sum of the flow is calculated using the flowmeter frequency output and the user entered K-Factor.
 Sum Flow = Flow 1 + Flow 2

NOTE: Additional calculations are used for Corrected Volume and Mass applications

Output Results:

- Display Results
 Flow 1, Flow 2, Sum Flow Rates, Resettable Totals, Non-Resettable Totals
- Analog Output
 Sum Rate or Sum Total
- Pulse Output
 Sum Total
- Relay Outputs
 Sum Rate or Sum Total Alarms

Applications:

The Flow Computer can monitor actual sum of two flow rate and two totals of any liquid. (Common applications include compound flowmeters) Flow alarms are provided via relays and datalogging is available via analog (4-20mA) and serial outputs.

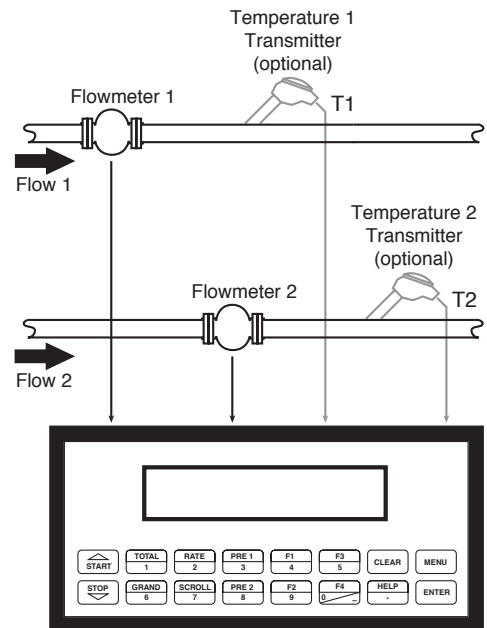

Calculations

Pulse Input; Average K-Factor

$$\text{Supply 1 or Supply 2 Flow} = \frac{\text{input frequency} \cdot \text{time scale factor}}{\text{K-Factor}}$$

$$\text{Sum Flow} = \text{Supply Flow 1} + \text{Supply Flow 2}$$

990346 03/01/15

Specifications:

Flow Meters and Computations

Meter Types: Supports pulse producing meters including: vortex, single rotor turbine, magnetic, PD flowmeter, Coriolis and compound flowmeters

Linearization: 40 point table, UVC table or Strouhal/Roshko

Computations: Volume, Corrected Volume & Mass

Fluid Computations: Density, Temperature, Viscosity in individual lines when needed

Environmental

Operating Temperature: 0°C to +50°C

Storage Temperature: -40°C to +85 C

Humidity : 0-95% Non-condensing

Materials: U.L. approved

Approvals: CE Compliant, UL/CUL Listed

Display

Type: 2 lines of 20 characters, Backlit LCD, OLED or VFD

Character Size: 0.2" nominal

User programmable label descriptors and units of measure

Keypad

Keypad Type: Membrane Keypad with 16 keys

Keypad Rating: Sealed to NEMA 4X / IP65

Enclosure

Size: See Dimensions

Depth behind panel: 6.5" including mating connector

Type: DIN

Materials: Plastic, UL94V-0, Flame retardant

Bezel: Textured per matt finish

Fluid Types

General Purpose, User entry of fluid properties for up to 10 fluids.

Real Time Clock

The 923-ST1-SUM-FC is equipped with a battery backed real time clock with display of time and date.

Format:

12 or 24 hour time display

Day, Month, Year date display

Excitation Voltage

Menu Selectable: 5, 12 or 24 VDC @ 100 mA (fault protected with self resetting fuse) DC powered units have limited selections.

Relay Outputs

The relay outputs are menu assignable to (Individually for each relay) Low Rate Alarm (sum of rate or sum of total), Hi Rate Alarm (sum of rate or sum of total), Temperature, Density or General purpose warning (security).

Number of relays: 2 (4 optional)

Contact Style: Form C contacts

Contact Ratings: 5 amp, 240 VAC or 30 VDC

Capabilities: Alarm Delay, Setpoint, Hysteresis, Duration

Power Input

The factory equipped power option is internally fused. An internal line to line filter capacitor and MOV are provided for added transient suppression.

110 VAC Power: 85 to 127 Vrms, 50/60 Hz

220 VAC Power: 170 to 276 Vrms, 50/60 Hz

DC Power:

12 VDC (10 to 14 VDC)

24 VDC (14 to 28 VDC)

Power Consumption:

AC: 11.0 VA (11W)

DC: 300 mA max.

Flow Inputs:

Pulse Inputs:

Number of Flow Inputs: 2

Input Impedance: 10 K Ω nominal

Pullup Resistance: 10 K Ω to 5 VDC (menu selectable)

Pull Down Resistance: 10 K Ω to common

Trigger Level: (menu selectable)

High Level Input

Logic On: 3 to 30 VDC

Logic Off: 0 to 1 VDC

Low Level Input (mag pickup)

Sensitivity:

10 mV or 100 mV

Minimum Count Speed:

Menu selectable: 1-99 seconds

Maximum Count Speed:

Menu Selectable: 40Hz, 3000Hz or 20 kHz

Overvoltage Protection: 50 VDC

Control Inputs

Switch Inputs are menu selectable for Reset, Lock, Inhibit, Alarm Acknowledge, Print, or Not Used.

Control Input Specifications

Number of Control Inputs: 3

Input Scan Rate: 10 scans per second

Logic 1: 4 - 30 VDC

Logic 0: 0 - 0.8 VDC

Input Impedance: 100 K Ω

Control Activation:

Positive Edge or Pos. Level based on product definition for switch usage.

Auxiliary / Compensation Inputs

The auxiliary/compensation inputs are menu selectable for meter 1 temperature, meter 2 temperature or not used. These inputs are used for the compensated inputs when performing compensated flow calculations. They can also be used as a general purpose input for display and alarming.
Number of inputs: 2

Operation: Ratiometric
Accuracy: 0.02% FS at 20° C
Basic Measurement Resolution:
 16 bit
Update Rate: 1 update/sec minimum
Automatic Fault detection:
 Signal Over-range/under-range
 Current Loop Broken
 Fault mode to user defined default settings

Fault Protection:
 Reverse Polarity: No ill effects
 Over-Voltage Limit (Voltage Input): 50 VDC

Available Input Ranges
 Current (Two): 4-20 mA, 0-20 mA
 RTD: (One) 100 Ohm DIN RTD Standard Three Wire
 Thermistor (One) - Consult Factory

Isolated Analog Output

The analog output is menu assignable to correspond to the Sum Rate/Total, Temperature, Density.
Type: Isolated Current Sourcing
Available Ranges: 4-20 mA, 0-20 mA
Resolution: 12 bit
Accuracy: 0.05% FS at 20° C
Update Rate: 1 update/sec minimum
Temperature Drift: Less than 200 ppm/C
Maximum Load: 1000 ohms (at nominal line voltage)
Compliance Effect: Less than .05% Span
60 Hz rejection: 40 dB minimum
Calibration: Operator assisted Learn Mode
Averaging: User entry of damping constant to cause a smooth control action

Isolated Pulse output

The isolated pulse output is menu assignable to Sum Total.
Pulse Output Form: Photo MOS Relay
Maximum On Current: 100 mA
Maximum Off Voltage: 30 VDC
Saturation Voltage: 1.0 VDC
Maximum Off Current: 0.1 mA
Pulse Duration: 10 mSec or 100 mSec (user selectable)
Pulse output buffer: 256
Fault Protection
 Reverse polarity: Shunt Diode

Serial Communication

The serial port can be used for printing, data recording, and/or communication with a computer.

RS-232:
 Device ID: 01-99
 Baud Rates: 300, 600, 1200, 2400, 4800, 9600, 19200
 Parity: None, Odd, Even
 Handshaking: None, Software, Hardware
 Print Setup: Configurable print list and formatting
RS-485: (optional 2nd COM port)
 Device ID: 01-247
 Baud Rates: 2400, 4800, 9600, 19200
 Parity: None, Odd, Even
 Protocol: Modbus RTU (Half Duplex)

Setup CD Capabilities

Capabilities include: View Live Results Configure unit, Upload and Download to unit, Load and Save to file, Print Setup,

Data Logging Capabilities

Capabilities:
 Permits unit to automatically gather data during use.
Data Log List:
 User selectable: includes Meter1/Meter2 Temperatures, Meter 1/Meter 2 Density, Meter 1/Meter 2 Viscosity, Meter 1, Meter 2 and Sum Ratemeters/Totalizers, Grand Totalizer, Time and Date, Fluid, Setpoint 1 & 2, Frequency 1 & 2, K-Factor 1 & 2.
Data Log Event Trigger:
 selectable: includes interval, time of day, front key, external contact
Data Log Format:
 selectable: Printer format, Database CSV format
Data Transmission:
 Selectable: Output may be transmitted immediately or held in data log for later polling
Remote Request Capabilities include:
 Send data log, clear data log

External Modem Support Capabilities:

Compatibility: Hayes Compatible
Polling Capabilities:
 Answers incoming calls, responds to requests for information of action
Call Out Capabilities:
 Can initiate call on user selectable event condition, or upon error
Error Handling:
 Supports multiple retry, automatic disconnect upon loss of line or remote inactivity

Fig. 1: Standard Dimensions

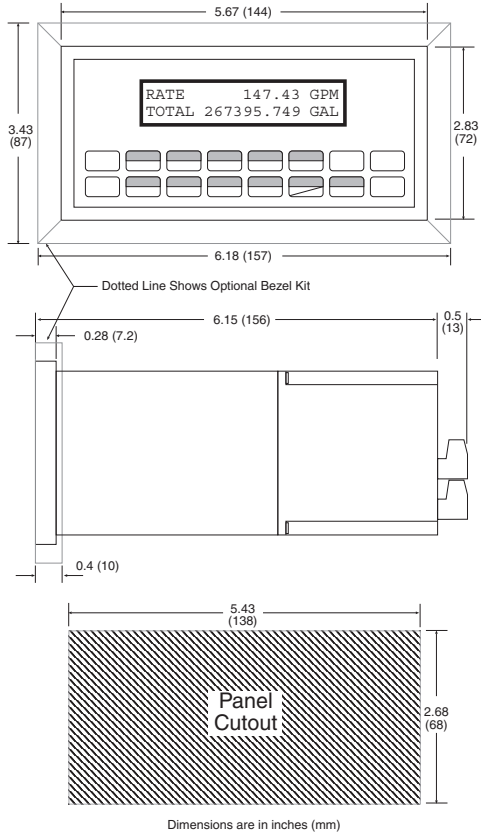
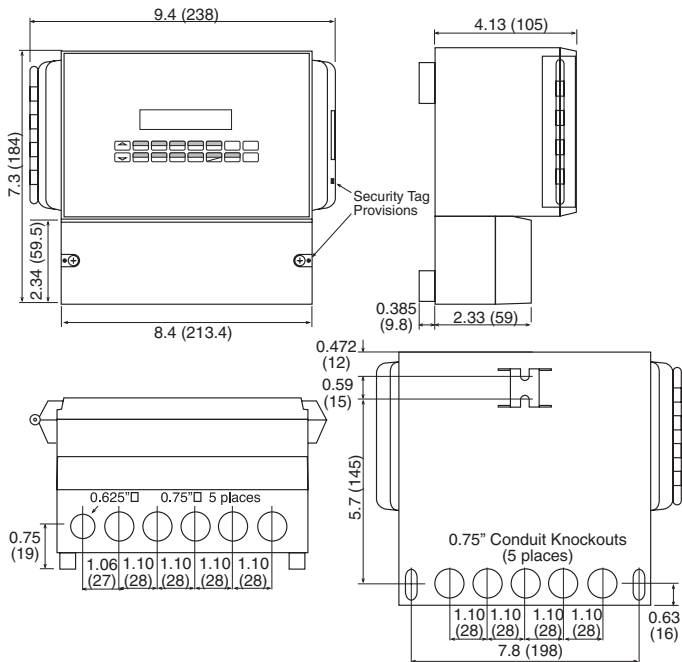

Fig. 2: Wall Mount (“W” mounting option) Dimensions



Terminal Designations

1	DC OUTPUT	FLOW	
2	PULSE IN 1	IN	
3	PULSE IN 2		
4	COMMON		
5	RTD EXCIT +	Vin +	Temp. 2
6	RTD SENS +	Thermistor	Temp. 1
7	RTD SENS -	in +	Temp. 1
8	RTD SENS -	in +	Temp. 2
9	CNTR IN 1		
10	CNTR IN 2		SEE USER
11	CNTR IN 3		MANUAL
12	COMMON		
13	PULSE OUTPUT +		
14	PULSE OUTPUT -		
15	ANALOG OUTPUT +		4-20 mA
16	ANALOG OUTPUT -		
17	NC	COM RLY1	COM RLY3
18	COM RLY1	26	NO
19	NO	27	NO
20	NC	COM RLY2	COM RLY4
21	COM RLY2	28	NO
22	NO	29	NO
23	AC LINE	DC +	POWER IN
24	AC LINE	DC -	

Terminal Layout

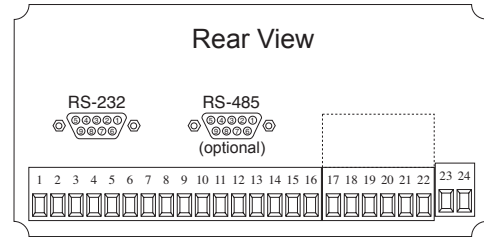

Ordering Information

Example 923-ST1SUMFC L 1 A 0 P TB

Series: _____

Display Type: _____

- L= LCD
- O= OLED
- V= VFD

Input Type: _____

- 1= 110 VAC
- 2= 220 VAC
- 3= 12 VDC (10 to 14 VDC)
- 4= 24 VDC (14 to 28 VDC)

Relays: _____

- A= 2 SPDT Relays
- B= 4 SPDT Relays (optional)

Network Card: _____

- 0= None (STD)
- 2= RS485/Modbus (optional 2nd COM port)

Mounting: _____

- P= Panel Mount (see Fig. 1)
- N= NEMA 4 Wall Mount
- W= NEMA 12/13 Wall Mount w/ Clear Cover (see Fig.2)
- E= Explosion Proof (No Button Access)

Options: _____

- TB= RS485 Terminal Block for Panel Mount Enclosure
- ET= Extended Temperature
-4°F to 131°F (-20°C to 55°C)
- IM = Internal Modem
- M = Modem Power Option

Accessories:

- OPC/DDE Server for RS232 Port available, see EX5-UCOND-NA00
- OPC/DDE Server for Modbus Suite available, see EX5-MDBUS-NA00
- Modem Available, see MPP-56KN and MPP-2400N
- Serial printer available, see P1000, P295
- Ethernet Port Server available, see IEPS
- Ethernet Port Server Modbus TCP available, see ADAM4572
- RS-422/485 to RS-232 Communication Adapter available, see CA285
- RS232 Extender Cable: P/N=13220-<length in inches>