

920-KRT

8 Digit LED Ratemeter & Totalizer

Features

- Pulse or Analog Input Ordering Options
- Display Total, Rate or Grand Total
- Two Alarm Outputs, User Selectable for Total, Rate or Grand Total
- Pulse Input to 20 kHz Count Frequency
- K-Factor Programmable to 8 Places
- Password Protection
- Two Way RS232/422/ Communications Option
- NEMA 4X/IP 65 Front Panel



- Scalable Analog Output of Rate or Total (optional)
- 16 Point Linearization Option

Description:

Featuring 8 digits of bright, .55", alphanumeric display, the pulse input version of the 920-KRT can accept up to 20,000 pulses per second. The analog input version accepts inputs, such as 4 to 20mA or 1 to 5V. The standard 920-KRT has two separate, 8 digit, floating decimal, "K" factors to convert the inputs to meaningful total and rate data. An optional 16 point K-factor can linearize flow from meter outputs. The user, with the push of a button, can toggle back and forth to view the total, the rate of flow and the grand total count. Two control outputs can be assigned independently by the user to activate at preset limit of total, rate or grand total for .1 to 9.9 seconds or until reset.

A scaled pulse output is also provided by an open collector driver. Since the output frequency is user selectable at 10, 200, 2K or 20K Hz, the unit can transmit the total data to remote electromechanical or electronic totalizers as well as computers, programmable controllers or other monitor equipment.

An optional analog output allows the user to select low and high settings to control strip chart recorders or other peripherals.

Up to 15 units can be connected to optional RS232 or RS422 communications port to set control points or access data.

Specifications:

Display: 8 Digit, .55" High, 15 Segment, Red Orange, LED.

Input Power (Internally Fused)

A: 110 VAC ±15% or 12 to 27 VDC

B: 220 VAC ±15% or 12 to 27 VDC

Current: Maximum 250mA DC or 3.2VA (3.2W) at rated AC voltage.

Output Power: (On AC powered units only)

+12 VDC at 100mA. Separate Isolated 12 VDC at 100mA to allow +12 VDC or +24 VDC regulated ±5% worst case.

DC Outputs are supplied with resettable fuses.

Memory: EEPROM stores all program and total data for minimum of 10 years if power is lost.

Pulse Inputs:

3A: Standard, High impedance pulse input. Open or 0 to 1 VDC (low), 3 to 30 VDC (high), 10K Ohm impedance, 20 kHz max. input speed (min. on/off 25 μsec.).

3B: Same as 3A but has 4.7K Ohm input pull up resistors to +5 VDC on input for pulsing with contact to ground or NPN open collector transistor.

Analog Inputs:

The current loop or voltage input is converted to a highly linear 0 to 10 kHz frequency. This frequency can then be scaled by the 8 digit K-Factors to total or display rate in separate engineering units.

Accuracy over full temperature range:

Zero error: +0.175% full scale max.

Overall error: +0.5% full scale max.

5A/7A: 4-20mA, 250 Ohm impedance

5B/7B: 0-20mA, 250 Ohm impedance

5C/7C: 1-5 VDC, 15K Ohm impedance

5D/7D: 0-5 VDC, 15K Ohm impedance

5E/7E: 0-10 VDC, 15K Ohm impedance

6A: 4-20 mA, Square Law, 250 Ohm impedance

Reset:

Front push button: "Clear" resets displayed number and control output. Remote: 3 to 30 VDC positive edge resets the totalizer and control output. Impedance: 10K to ground
 Minimum pulse: 5 msec.

Temperature:

Operating: +32°F (0°C) to +130°F (+54°C).

Storage: -40°F (-40°C) to +200°F (+93°C).

ET: Extended Temperature -40° to 158°F (-40° to 70° C)

ET not available with analog inputs or outputs

Humidity: 0-90% Noncondensing

Listing: CE Compliant

Totalizer: Each of the total and grand total counters have 8 digits. In the set-up mode choose "R0" (reset to zero) for adding operation or "SP" (set to preset) for subtracting operation. While viewing the total, the display can be made to flash the grand total by pressing "ENT". Activating "CLR" while the grand total is flashing, resets the grand total counter.

Ratemeter: Accurate to 5 1/2 digits (± 1 display digit). The rate meter can be programmed to accept almost any number of pulses per unit of measurement for pulse rate as low as one pulse every 24 seconds, and autorange up to 6 digits of significant information. The rate meter with a "K" factor of 1 displays the rate of pulses per second. Simply dial in the proper "K" factor to display in minutes, hours or other units of measurement. Press the "C" button while the unit is displaying the total to display the rate as indicated by "R" displayed on the left side of the display.

Password Lockout: Two stage lockout is available for allowing change of presets only or total lockout of front panel parameter changes. Unauthorized front panel changes can be prevented by entering a user selected four digit password code.

Factored Output: The 920-KRT gives one pulse out for each factored total count. Open collector sinks 30 VDC maximum to 1 volt maximum at 100mA maximum. Output speed is user selectable (see table below). An internal buffer holds up to 10,000 pulses for output at the selected frequency before "DATA LOST" flashes, indicating output pulses were lost. If factored rate exceeds 7 digits "RFF..." flashes. This alarm indicates that the maximum displayed rate has been exceeded.

Speed (Hz)	10	200	2000	20000
Min. on/off (mSec)	47.5	2.0	0.2	0.013

Control Outputs: (Each of two outputs)

1. NPN Transistor Version: (Optional)
Open collector sinks max. 250mA from 30 VDC when active.
2. SPDT Relay Version:
10A 120/240 VAC or 28 VDC (Standard).

Analog Output: Digital input or analog input (except Square Law) versions can be ordered with an analog output of the rate or total reading. User keys in the low and high settings at set-up.

Current Outputs:

A sinking driver generates a corresponding linear current through the external devices, updating with each update of the rate display. Accuracy is $\pm 5\%$ worst case. Compliance voltage must be 3 to 24 VDC, non inductive. (The 920-KRT can provide the DC source as long as the drop across all devices being driven does not exceed 21 V).

Voltage Outputs:

When the voltage out option is ordered, a controlled voltage output is located at terminal 3 and referenced to pin 12 (ground). Accuracy is $.1\% @ 20^\circ\text{C}$ (max. drift $.01\%/^\circ\text{C}$).

Preset Alarms: Two control alarms are provided on the 920-KRT. The preset numbers can be made to flash without interrupting the control function by pressing "A" (Preset A) or "B" (Preset B). Press "ENT" to return to rate or total display. Change the preset by clearing the flashing preset number and keying in a new setpoint number before pressing the "ENT" button. (Count pulses may be lost if the preset is changed while pulses are coming in.) In the "Relay Set-Up" the user selects either or both preset outputs to be activated by the total, grand total or rate. If selected for total or grand total the outputs can be set to activate at the preset total for 0.1 to 9.9 seconds or latch (0.0 setting) until reset. If selected for rate control, the rate will be compared with the preset at each display update and the output activated if the rate is equal to or greater than the preset. The output drops out again only if the rate drops below the preset. If the rate goes out of scale the display will show all "F" and the output will remain in the state prior to going out of scale.

K-Factor: In the standard unit a fixed K-Factor is used to convert the input pulses or frequency generated internally by the analog input to engineering units. The 8 digit K-Factor dividers, with decimal keyed into any position, allow easy direct entry of any K-Factor greater than 0.0001 to 99999999. Separate K-Factors

may be entered for the total and rate section. Thus, you may totalize in gallons and display rate in liters per hour. The maximum factored count speed is 20,000 Hz. The maximum factored rate is 7 digits.

16 POINT LINEARIZATION variable K-factor option makes flow systems more accurate and often extends their usable range by allowing users to dial in different K-factors for different flow rates. It works with either pulse input or standard analog current loop or voltage input. It is recommended for flow meters whose K-factors change with different rates of flow. From 3 to 16 points of frequency (0 to 10,000 Hz) and K-factors (.0001 to 999,999) are dialed in at set up. The unit uses 8 digit floating math to interpolate between settings. Rate per second, per minute or per hour programmability eliminates the need to calculate separate K-factors for total and rate.

Outcard: RS232 or RS422 serial two way communication options are available. Several units can be linked together and addressed separately to transmit unit status or accept new set points in the standard ASCII format. Baud rates of 300, 600, 1200, 2400, 4800 or 9600 as well as choice of odd, even, space or mark parity can be selected by keypad control.

Termination:

- 1 • NOT USED
- 2 • SCALED OUTPUT (OPEN COLLECTOR)
- 3 • ANALOG OUTPUT (SINK)
- 4 • INPUT (PULSE/ANALOG)
- 5 • RESET INPUT
- 6 • NOT USED
- 7 • NOT USED
- 8 • NOT USED
- 9 • NOT USED
- 10 • NOT USED
- 11 • GROUND (-DC)
- 12 • GROUND (-DC)
- 13 • 12 VOLTS OUT
- 14 • + DC POWER IN (12 to 27 VDC)
- 15 • ISOLATED -12 VOLTS OUT
- 16 • ISOLATED +12 VOLTS OUT
- 17 • AC INPUT
- 18 • AC INPUT
- 19 • PRESET B OPEN COLLECTOR
- 20 • PRESET A OPEN COLLECTOR

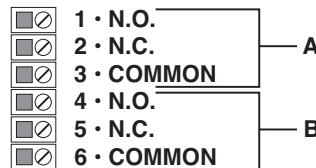

Pulse Output Wiring

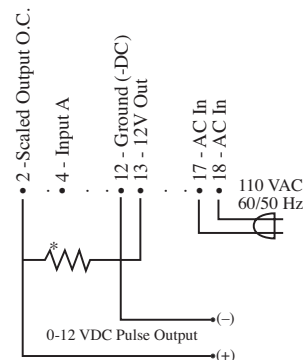

* Must be greater than 150 Ohms

Pulse Input With Analog Output

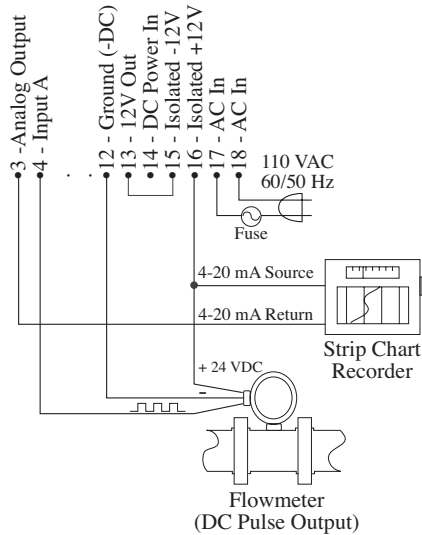

Dimensions:

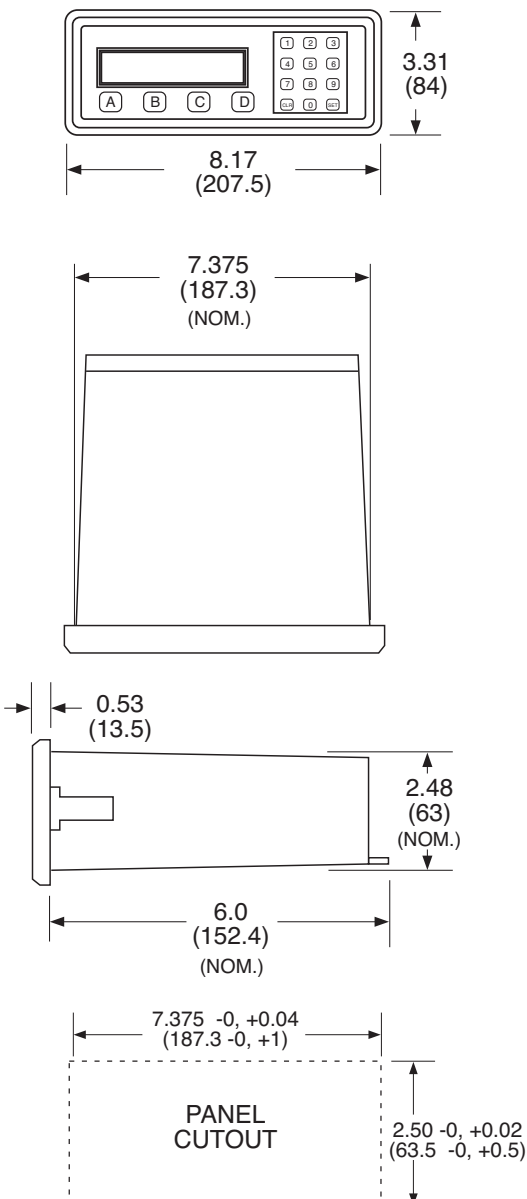

Ordering Information

Example 920-KRT8 A 3A 2 A 1 3

Series: _____

920-KRT

Operating Voltage: _____

A: 110 VAC $\pm 15\%$ or 12 to 27 VDC

B: 220 VAC $\pm 15\%$ or 12 to 27 VDC

Control Inputs: _____

* 3A: STD Pulse 3-30 VDC 20 kHz Max.

* 3B: As 3A, with 4.7 K Ω pull up resistors

5A: 4-20 mA

5B: 0-20 mA

5C: 1-5 VDC

5D: 0-5 VDC

5E: 0-10 VDC

6A: 4-20 mA Square Law

7A: 4-20mA in, 4-20mA out

7B: 0-20mA in, 4-20mA out

7C: 1-5VDC in, 4-20mA out

7D: 0-5VDC in, 4-20mA out

7E: 0-10VDC in, 4-20mA out

For Other Outputs:
Add X for 0-20mA out
Add Y for 0-5V out
Add Z for 0-10V out

Control Outputs: _____

1: Open Collector (optional)

2: SPDT Relay 10A (standard)

Input Speed: _____

* A: 0-40 CPS (Inputs 3A, 3B)

* C: 0-400 CPS (Inputs 3A, 3B)

* E: 0-20K CPS (Inputs 3A, 3B)

* K: Inputs 5A-5E, 6A, 7A-7E

* Dip switch selectable,
all units can be field modified easily.

Options: (Multiple Options Available) _____

1: RS232 Serial Interface

2: RS422 Serial Interface

3: 4-20 mA Output (Input 3A or 3B only)

3X: 0-20 mA Output (Input 3A or 3B only)

3Y: 0-5VDC Output (Input 3A or 3B only)

3Z: 0-10VDC Output (Input 3A or 3B only)

4: 16 Point Linearization Opt.

ET: Extended Temperature:

-40° to 158°F (-40° to 70° C)

ET not available with analog inputs or outputs

UL/CSA: UL/CSA Approved Unit (pending) ..(consult factory)

Accessories:

NEMA4x1: NEMA 4X/IP 65 Enclosure for wall mounting,
accommodates 1 unit.

NEMA4x2: NEMA 4X/IP 65 Enclosure for wall mounting,
accommodates 2 units.

XTROL7/4- Explosion proof housing

P1000 - Serial printer

P295 - Serial printer

IEPS - Ethernet Port Server

CA285 - RS-422/485 to RS-232 Communication Adaptor



Flowmetrics, Inc.

"Where Quality is Measurable"

9201 Independence Avenue • Chatsworth, CA 91311
(818) 407-3420 • FAX (818) 700-1961

<http://www.flowmetrics.com>