

917-BATRAT-M

Battery Powered Ratemeter & Totalizer with Alarm Output

Features

- UL/C-UL Intrinsically Safe Listed
- Magnetic Pickup Input, Contact Closure Input, DC Pulse Input (Optically Isolated)
- Displays Rate & Total Simultaneously
- 5 Digit Rate Display, 8 Digit Totalizer Display
- 4-20mA Analog Output (optional)
- Powered From Internal Battery, External DC Supply or 4-20 mA Output Loop
- 20 Point Linearization (optional); 10 Point Linearization with Data Logger option
- Isolated High/Low Flow Rate Alarm Output
- Nonvolatile Flash Memory of Setup Data
- RS485 Modbus Communications and Data Logger (optional)
- Setup Software Available for Easy Programming and Monitoring Using a PC and Special Serial Cable (optional)

Description

Featuring 5 digits of rate and 8 digits of total, the 917-BATRAT-M is a battery powered indicator with flow rate alarm output. It is capable of accepting magnetic pickup, DC pulse and switch closure inputs from pulse producing flowmeters. The unit can be ordered with an optional 4-20mA output. When this option is used, it uses the 4-20mA loop to provide power when this output is used. The 917-BATRAT-M is available with an optional setup program (S1 Option). Alternately it is available with a RS485 Modbus RTU communications and a datalogger.

Specifications

Display:

Rate Display: (selectable decimal)

5 Digits (99999), 0.35" High, Display updates once per second with battery power, 8X per second with DC or Loop power. (Slow input pulse rates, large delay setting and internal math operations may delay the update rate.)

Rate Descriptors: /SEC, /MIN, /HR
/MIN, /HR, /DAY with "D" option

Min. Input Frequency: 0.01 Hz to 10 Hz (selectable delay of 0.1 to 99.9 seconds)*

Selectable Rate Display Damping

Totalizer Display: (selectable decimal)

8 Digits (99999999), 0.2" High
Totalizer Descriptors: GAL, LIT, FT3, M3, "blank"
GAL, BBL, MCF, M3, "blank" with "D" option

Warning Displays: Low battery warning



Mounting Style 1



Mounting Style 3



Mounting Style 3SS



Mounting Style 5



Mounting Style 6

Alarm Output:

Combination High-Low flow rate alarm output activates when flow rate is less than low set point or greater than high set point.

Type: Opto-isolated photomos relay

Max. voltage (off state): 30 VDC

Current (on state): 100 mA

Power:

BATTERY POWERED

Supplied with 2 C size Lithium battery pack.

EXTERNAL POWER INPUT

Voltage: 8.5 to 30 VDC

Current: Less than 5 mA

Supplied with 1 C size lithium battery for standby operation

Protection: Reverse Polarity Protection on DC Power Input

LOOP POWERED

Voltage: 8.5 to 30 VDC

Supplied with 1 C size lithium battery for standby operation

Protection: Reverse Polarity Protection on Current Loop

Loop Burden: 8.5V maximum

BATTERY LIFE EXPECTANCY:

Expected Years of Operation for 917-BATRAT-M of various powering options at equipment duty cycles

MODEL		RUN TIME			
		Idle	2hrs/day	8hrs/day	24hrs/day
917-BATRAT-M-A		10 yrs	10 yrs	10 yrs	9.1 yrs
917-BATRAT-M-A-4		10 yrs	10 yrs	10 yrs	8.4 yrs
917-BATRAT-M-B/C		10 yrs	10 yrs	10 yrs	10 yrs
standby-operation					
917-BATRAT-M -B/C		Indefinite operation when externally powered			
External or loop power					

NOTE: Battery shelf life is rated at 10 years by manufacturer Life expectancy based on rated battery capacity at 20°C The above table is shown with pulse output inactive. Use of alarm output shortens battery life.

MOUNTING STYLES:

- 1- Panel Mount - NEMA 4X Front
- 3- Explosion Proof - Class I, Division I, Groups B, C & D Class II, Division I, Groups E, F & G
- 3SS- Explosion Proof - Stainless Steel Class I, Division I, Groups B, C & D Class II, Division I, Groups E, F & G
- 5- Wall Mount - NEMA 4X Enclosure (keypad mounted on cover)
- 6- Double Ended Explosion Proof - Class I, Division I, Groups B, C & D Class II, Division I, Groups E, F & G (contact factory for details)

Environmental:

OPERATING TEMPERATURE

-4°F (-20°C) to + 158°F (70°C)

Extended Temp: -22°F (-30°C) to + 158°F (70°C)

HUMIDITY

0 - 90% Noncondensing

ACCURACY:

0.01% Reading, ±1 count

Temperature Drift: 50 ppm/°C Worst Case

SAFETY LISTINGS (Mounting Styles 3, 3SS):

CSA File 091109 (cert. 1120094)

UL/C-UL File E225832

CLASS 1, DIV 1, GROUPS B, C, D

Additional "enclosure only" approvals available for ATEX and IEC

INPUTS:

MAGNETIC PICKUP INPUT

Frequency Range: 0 to 3500 Hz

Trigger Sensitivity: 10 mV p-p

Over Voltage Protected: ± 30 VDC

OPTO-ISOLATED DC PULSE INPUT

High (logic 1): 4-30 VDC

Low (logic 0): Less Than 1 VDC

Minimum Current: .5 mA

Hysteresis: 0.4 VDC

Frequency Range: 0 to 5 kHz

Min. Pulse Width: 0.1 msec

CONTACT CLOSURE INPUT (contact closure to common)

Internal Pullup Resistor: 100 KΩ to +3.6 VDC

High (logic 1): Open or 4-30 VDC

Low (logic 0): Less Than .5 VDC

Internal Switch Debounce Filter: 0 to 40 Hz

NOTE: Sustained contact closure will shorten battery life.

RESET INPUT (contact closure to common)

Internal Pullup Resistor: 100 KΩ to +3.6 VDC

High (logic 1): Open or 4-30 VDC

Low (logic 0): Less Than .5 VDC

Minimum On : 25 msec

NOTE: Sustained contact closure will shorten battery life.

K-FACTOR

Range: 0.001 to 99999999

Decimal Point Locations: XXXX.XXXX to XXXXXXXX

20 Point Linearization Option (10 Point with S2 option)

This feature allows the user to enter 20 different frequencies with 20 different corresponding K-Factors to linearize non linear signals.

ANALOG OUTPUT OPTION:

Type: 4-20 mA follows rate display, Two wire hookup

Accuracy: 0.025% Full Scale at 20° C

Temperature Drift:

50 ppm/°C Typical

Reverse Polarity Protected

Update Rate: 8 times/second

NOTE: The 917-BATRAT-M uses the 4-20 mA loop power as its primary power source when this option is used. The battery is still required for standby battery operation.

DATA STORAGE:

Setup Information: Stored in flash memory

Totalizer: Stored in battery backed RAM but can be saved to flash memory by operator for recall after battery change out.

COMMUNICATIONS OPTION (S1):

RS232 SERIAL SETUP SOFTWARE OPTION:

This option enables you to access a variety of process parameters through serial communications. PC compatible communications software is included with this option. With this software and a 917-BATRAT-M Serial Adapter Cable (BSAC1) you will be able to setup the 917-BATRAT-M through your PC.

RS-485 MODBUS and DATA LOGGER OPTION (S2):

The optional RS-485 card utilizes Modbus RTU protocol to access a variety of process parameters. The Data Logger stores the totalizer to flash memory once every 24 hours at the time you set. The data logger can hold 26 days of totals, on the 27th day the oldest total in the logger is dropped. Requires external DC power: 6-28VDC (input is reverse polarity protected)

Current Draw:

Receiving: 2 mA

Transmitting: 125 mA (instantaneous peak)

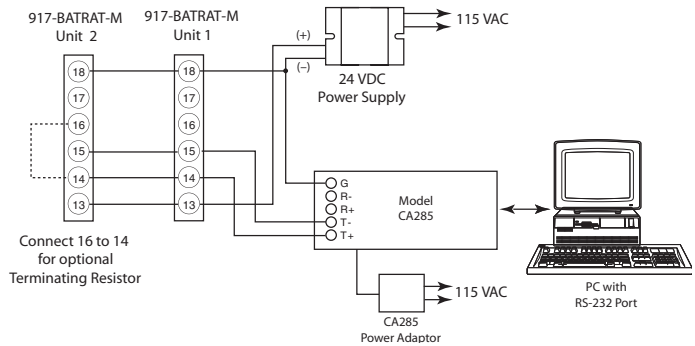

Typical Wiring:

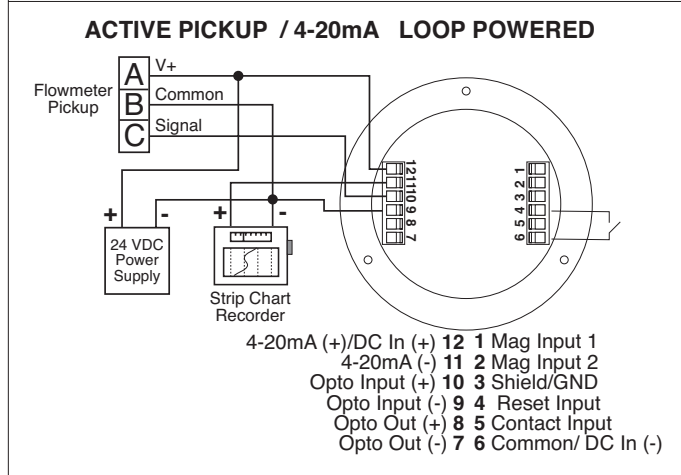
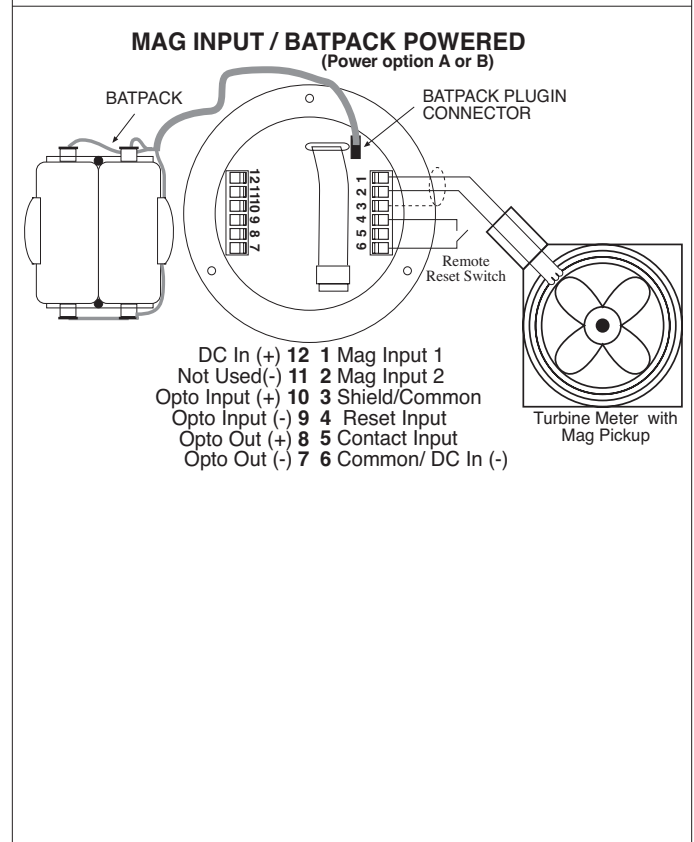
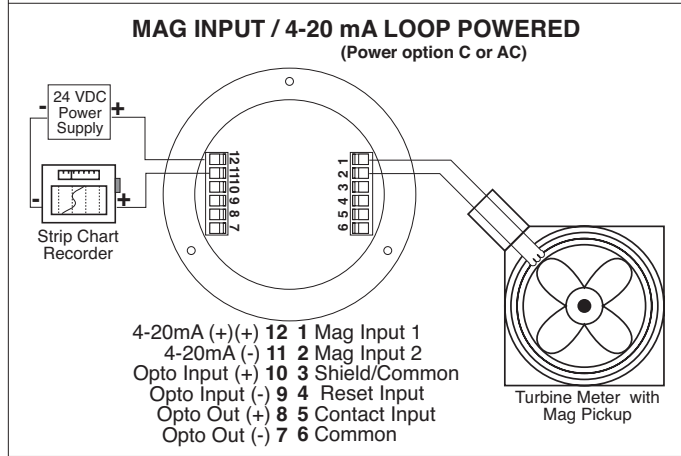
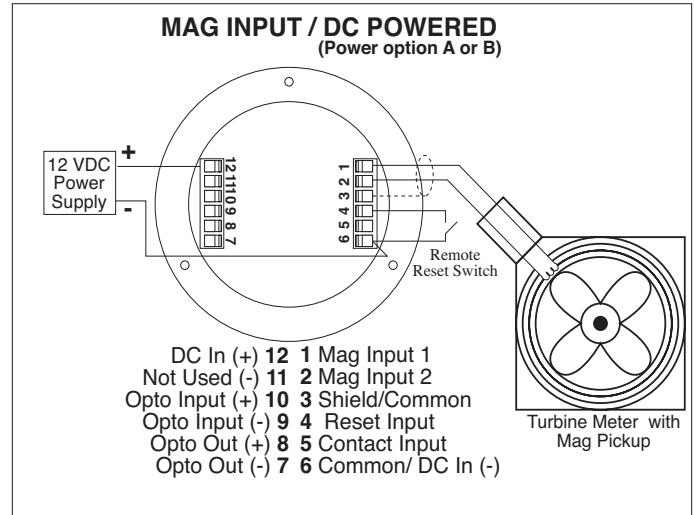
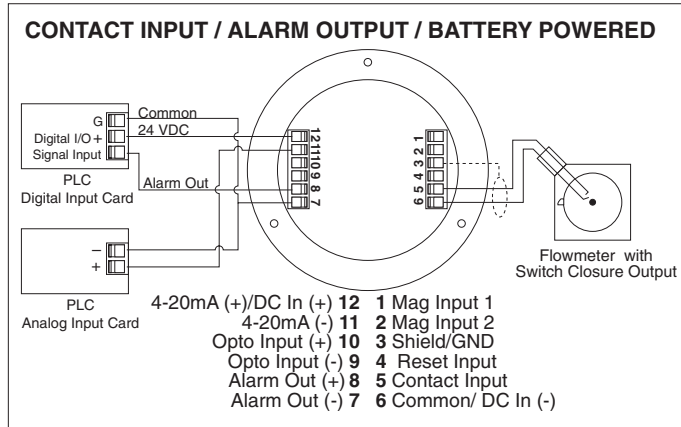

BATPACK

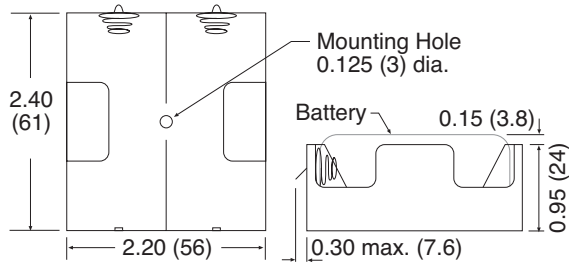

917-BATRAT-M-1

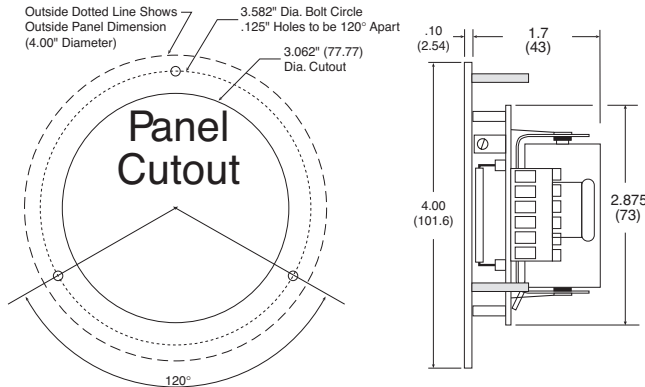

917-BATRAT-M-3

To access terminals, unscrew cover and loosen 2 panel screws. Terminals are on bottom side of PC board.

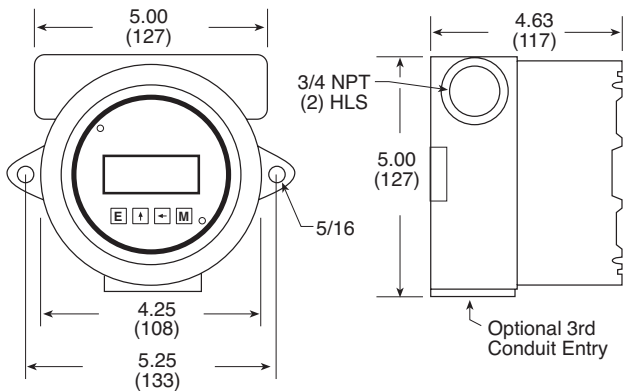

917-BATRAT-M-3SS

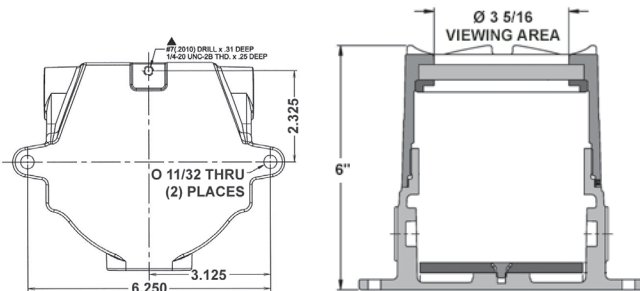

917-BATRAT-M-5

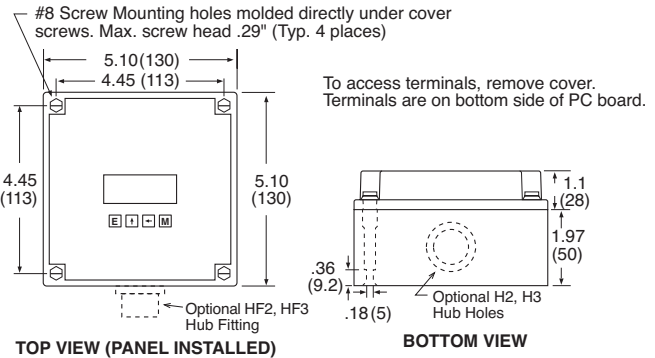

NOTE: Additional entry holes may be provided on style 5.

917-BATRAT-M-6

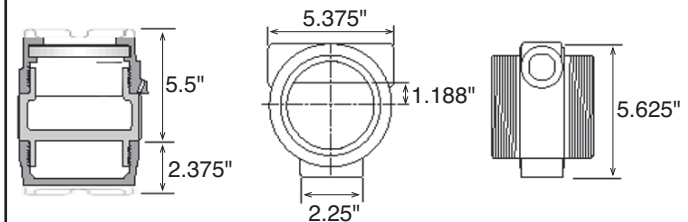

Ordering Information

EXAMPLE: 917-BATRAT-M 3 A 4 ET

Series:

Mounting:

- * 1 = Panel Mount
- 3 = Explosion Proof Housing
- 3SS = Stainless Steel Ex-Proof Housing
- 5 = NEMA 4X Box (917-BATRAT-M outside opaque cover)
- 6 = Double Ended Explosion Proof Housing (consult factory)

Power Supply:

- * A = Battery (2 supplied)
- B = External Power Supply (8.5 to 30 VDC)
- C = Loop Powered with 4-20 mA Output
- AC = Loop Powered with 4-20 mA Output and 2 Batteries

Options (Multiple Options Available)

- S1 = Serial Setup Software for use with BSAC1
- S2 = RS485/Modbus/Data Logger - Isolated (power options B, C only)
- 4 = 20 Point Linearization (10 point with S2 option)
- D = Rate per Day, Hour or Minute
- ET = Extended Temp.: -22°F to 158°F (-30°C to 70°C)
- CE** = CE Compliant
- CSA** = CSA Listed Explosion Proof
- IS** = UL Listed IS (planned)
- ATEXCASE** = European Flame Proof ATEX Case
- TRX = NEMA7 Explosion Proof Reset Switch (mounting style 3 and 6)
- RN = External Magnetic Reset
- T = Third Conduit Entry in Ex-Proof Housing (mounting style 3 and 6)
- H2 = 0.875" Hole for mounting style 5
- HF2 = 0.5" Female NPT Hub fitting for mounting style 5
- H3 = 1.125" Hole for mounting style 5
- HF3 = 0.75" Female NPT Hub fitting for mounting style 5

Accessories:

- BATPACK = External Batt. Pack with 2 C Size Batteries & 12" leads
- BATC = Single Battery: Tadiran P/N TL2200/S 3.6V 7200mAh or equal
- 115-24 = 115 VAC to 24 VDC power supply
- BSAC1 = RS232 Serial Adapter Cable with setup software

* External battery pack supplied with model 917-BATRAT-M1A

** Contact factory for latest information