

MB2 (MINI-Batcher)

Low Cost, Pulse Input Batch Controller

Features

- 5 Digit Scaling Factor
- Display Rate, Batch Size and (Batch Total or Grand Total)
- Second B Relay Programmable for Output at Prewarn or selected Batch/Grand Total
- Pulse Input - 10 kHz Max.
- Security Lockout
- RS422/RS232 Serial Communication
- NEMA 4X / IP65 Front Panel
- 30mV Magnetic Pickup Inputs
- 4-20mA or 0-20mA Analog Output



Application:

This miniature batcher is ideal for all batching applications. The display will show Batch Amount, Rate and Batch/Grand Total at the push of a button. The Start and Stop buttons make batching simple.

Description:

The MINI-Batcher is a 6 digit totalizer and 4.5 digit ratemeter with two relay outputs. One output is dedicated to the batch amount (Preset A), the other can be activated for Prewarn or Batch/Grand Total. The unit can count up to the preset (reset to 0) or down from the preset (set to preset). Start, Stop and Reset functions can be activated from the front panel or remote inputs.

An analog output (assignable for Rate or Batch Amount) is available for data logging.

Up to 99 units can communicate to a host computer on a single RS232 or RS422 loop.

Specifications:

Display: 6 digit, 0.55" High LED

Input Power:

- 110 VAC \pm 15% or 12 to 15 VDC
- 220 VAC \pm 15% or 12 to 15 VDC
- 24 VAC \pm 15% or 12 to 15 VDC

Current: 250 mA DC max. or 6.5 VA AC

Output Power: (AC powered units only)
+12 VDC @ 50 mA, unregulated -10 + 50%

Temperature:

Operating:
+32°F (0°C) to +130°F (+54°C)

Storage:
-40°F (-40°C) to +200°F (93°C)

Humidity: 0-90% Noncondensing

Memory: EEPROM stores data for 10 years if power is lost.

Approvals: CE Approved (optional), UL/CSA Pending

Inputs:

- 3: High Impedance DC pulse input 4-30 VDC (high), Open or 0-1 VDC (low), 10 k Ω imp. 10 kHz max. speed.
- 3M: Mag. Input, accepts 30mV input (50 V max.) signals 10 K Ω imp. 5 kHz max.

Stop / Reset:

Front Panel:

STOP/RST button stops batch if batch is running, Resets displayed value and control output if batch is stopped.

Remote:

4-30 VDC, positive edge: stops batch if batch is running, Resets batch amount if batch is stopped.

NOTE: Hold either front or remote reset active to inhibit any start inputs.

Scaling Factor (K-Factor): A user programmable K-Factor is used to convert the input pulses to engineering units. The 5 digit K-Factor divider, with decimal keyed into any position, allows easy direct entry of any K-Factor from 0.0001 to 99999.

Presets: Two control outputs are provided. A 5 digit value can be entered for both presets. The decimal point location is the same as the counter (No decimal in Batch Total counter).

PRESET A:

The preset A output is dedicated to the batch amount. When START is activated, Relay A will energize and remain on until the batch is complete or the batch is stopped.

PRESET B:

The preset B output can be programmed to activate as a Prewarn (for two stage batch control) or activate on Batch Total or Grand Total (selectable).

When set for PREWARN, Relay B will energize when START is activated and drop out at Prewarn number before preset.

When set for Batch Total or Grand Total, Relay B will activate when the batch total or grand total counts up to preset B amount. The output ON time can be set for a duration (0.01 to 99.99 sec.) or latched (0.00 setting). If a value other than 0.00 is set for the duration, the batch total or grand total will auto-reset at preset B.

Control Outputs:

Relays:

2 each N.O. Relay; 5 Amps 120/240 VAC or 28 VDC. (N.C. relay contacts and NPN transistor output available with solder jumpers.

Analog Output:

An optional 4-20mA (0-20mA) output is available for the Mini-Batch series. The output can be programmed to track rate or batch amount. Connections are via a 2 terminal pluggable screw connector. Programming is accomplished by using the front panel in conjunction with rear dip switches. Accuracy: $\pm 0.25\%$ FS worst case. Compliance Voltage: 3 to 30 VDC non inductive.

Lockout: Unauthorized front panel changes can be prevented by entering a user selected 5 digit code. The front panel can be completely locked out (except Start & Stop) or the preset can remain accessible.

Ratemeter: Accuracy: 0.01% FS (± 1 display digit).

The rate display updates once per second. The rate meter can be programmed to sample from 2 to 24 seconds maximum, and auto-range up to 5 digits of significant information. The ratemeter displays in units per second, minute or hour.

Batch or Grand Totalizer: In addition to viewing the batch amount, a second counter can be viewed. This counter is programmable to count either the number of batches (Batch Total) or the grand total count (Grand Total).

RS232/RS422 Serial Interface: If the serial interface option is supplied, up to 99 units can be linked together. (The terminal addressing the unit must be capable of driving all loads in the loop.) Unit status and new set points can be communicated by serial communication. Mode changes, however, must always be made on the front panel.

Dimensions:

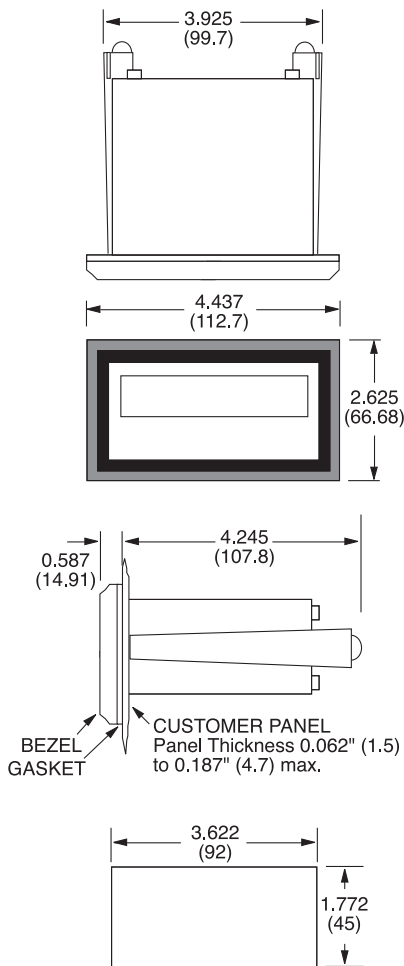

Wiring:

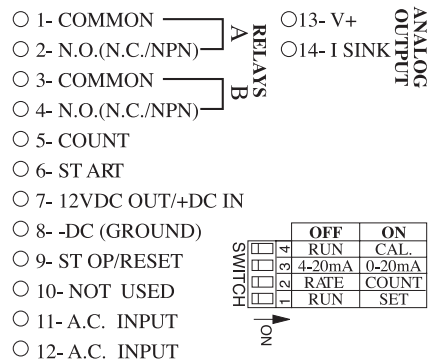

Ordering Information

Series:	914	MB2	A	3	1
MB2=	MiniBatcher				
Operating Voltage:	A= 110 VAC $\pm 15\%$ or 12 to 15 VDC B= 220 VAC $\pm 15\%$ or 12 to 15 VDC C= 24 VAC $\pm 15\%$ or 12 to 15 VDC				
Count Inputs:	3 = Standard, 4-30 VDC pulse inputs. 3M = Mag. Input, 30mV input				
Options	1= RS232 Communications 2= RS422 Communications A= Analog Output (4-20/0-20 mA) CE = CE Approved Version				
Accessories	XHV - Explosion proof housing (see accessories section) NEMA-1/8DIN- NEMA 4X enclosure (see accessories section) P1000- Serial Printer (see accessories section)				